



KADEY KROGEN 48



GRAND BANKS 72



NORDHAVN 47

TRAC[®]



8"-10"-12"

DC ELECTRIC THRUSTERS



During maneuvering, DC Thruster motors gain heat according to usage pattern. This usage, together with motor insulation rating, determines the available thruster run time. By forcing air over the motor windings between periods of thrusting, the optional cooling fan provides greater duty cycle for thruster use.

TRAC systems are extensively documented and delivered ready-to-install. Expert support is always available from factory technicians and through our global service network.

TRAC Thrusters are installed as standard equipment by more of the world's top yacht builders than any other brand. For exceptional performance, highest quality, and unmatched support, choose TRAC.

TRAC Thrusters deliver more thrust per horsepower than any other thruster available. TRAC's twin counter-rotating propellers are more efficient and can reach higher horsepower than single prop thrusters.

TRAC DC series stands in a class of its own. You will not find undersized propeller shafts, shear pins, light duty motors, inferior materials, or any other compromises in the DC TRAC. The DC TRAC is built with the same high standards of its higher horsepower hydraulic and AC electric counterparts.

One of the most important components of a DC thruster is the motor. TRAC DC motors are larger, heavy duty motors that extend run times to three minutes or more.



Single speed control. Low profile, ergonomic design. Spring-to-center or friction lock lever. Power ON indicator and audible alarm indicator. Single or dual configuration (bow and stern thruster).

Arcturus Marine. Taking Care Of You Every Step Of The Way.

ARCTURUSMARINE™
AMERICAN BOW THRUSTER™

517-A Martin Avenue, Rohnert Park, CA 94928 USA
TEL 707•586•3155 800•535•5377 FAX 707•586•3159
www.thrusters.com

TRAC

8"-10"-12"

DC ELECTRIC THRUSTERS

8"-10"-12" up to 12 HP

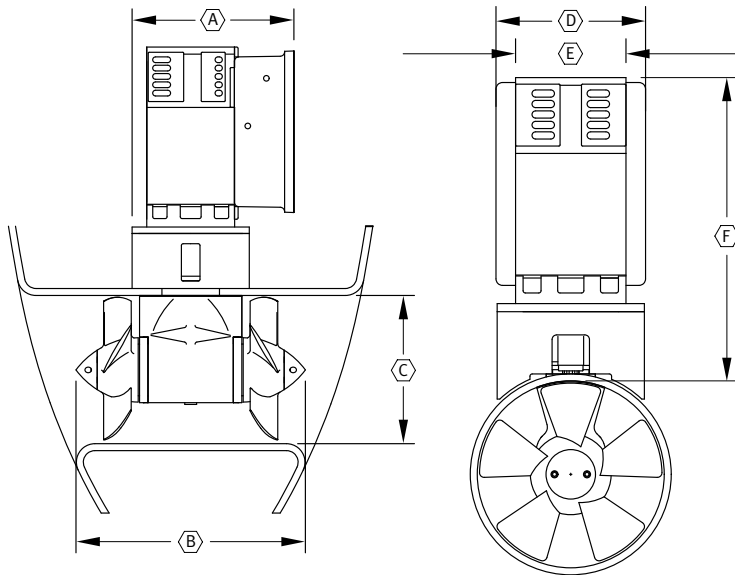

	8 INCH		10 INCH		12 INCH	
	in	cm	in	cm	in	cm
A	10.9	(27.69)	10.9	(27.69)	13.6	(34.54)
B	12.5	(31.75)	15.4	(39.12)	15.4	(39.12)
C	8.0	(20.32)	10.0	(25.4)	12.0	(30.48)
D	8.0	(20.32)	8.0	(20.32)	10.6	(26.92)
E	5.9	(15)	5.9	(15)	8.5	(21.59)
F	16.2	(41.15)	16.2	(41.15)	19.9	(50.55)

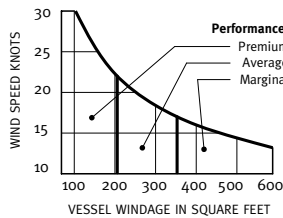

8 INCH

Performance

POWER	7.5 HP	5.6 KW
NOMINAL THRUST	200 LBS	91 KG
VOLTS	24 V	
AMPS	355	
CABLE SIZE	3/0	

Weights

	lbs	kg
THRUSTER	37 (17)	22 (10)
MOTOR	82 (37)	82 (37)

Battery

Minimum req. 2 each Group 31

BRONZE

ALUMINUM

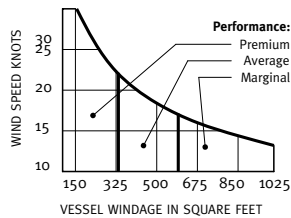

10 INCH

Performance

POWER	10 HP	7.5 KW
NOMINAL THRUST	285 LBS	129 KG
VOLTS	24 V	
AMPS	470	
CABLE SIZE	4/0	

Weights

	lbs	kg
THRUSTER	63 (29)	36 (16)
MOTOR	87 (39)	87 (39)

Battery

Minimum req. 2 each 8-D

BRONZE

ALUMINUM

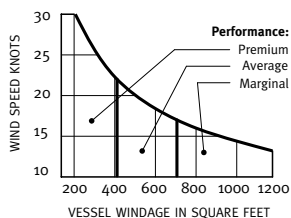

12 INCH

Performance

POWER	12 HP	9 KW
NOMINAL THRUST	342 LBS	155 KG
VOLTS	24 V	
AMPS	535	
CABLE SIZE	250 MCM	

Weights

	lbs	kg
THRUSTER	68 (31)	38 (17)
MOTOR	159 (72)	159 (72)

Battery

Minimum req. 2 each 8-D

BRONZE

ALUMINUM

Dimensions shown for reference only and are subject to change. Do not use for installation.